

1

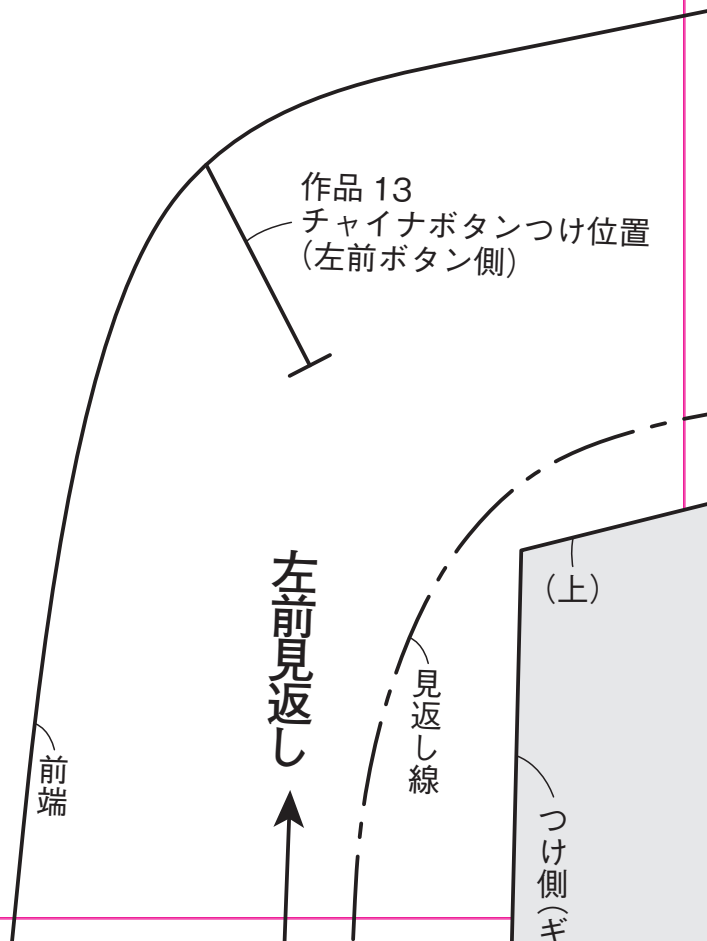

2

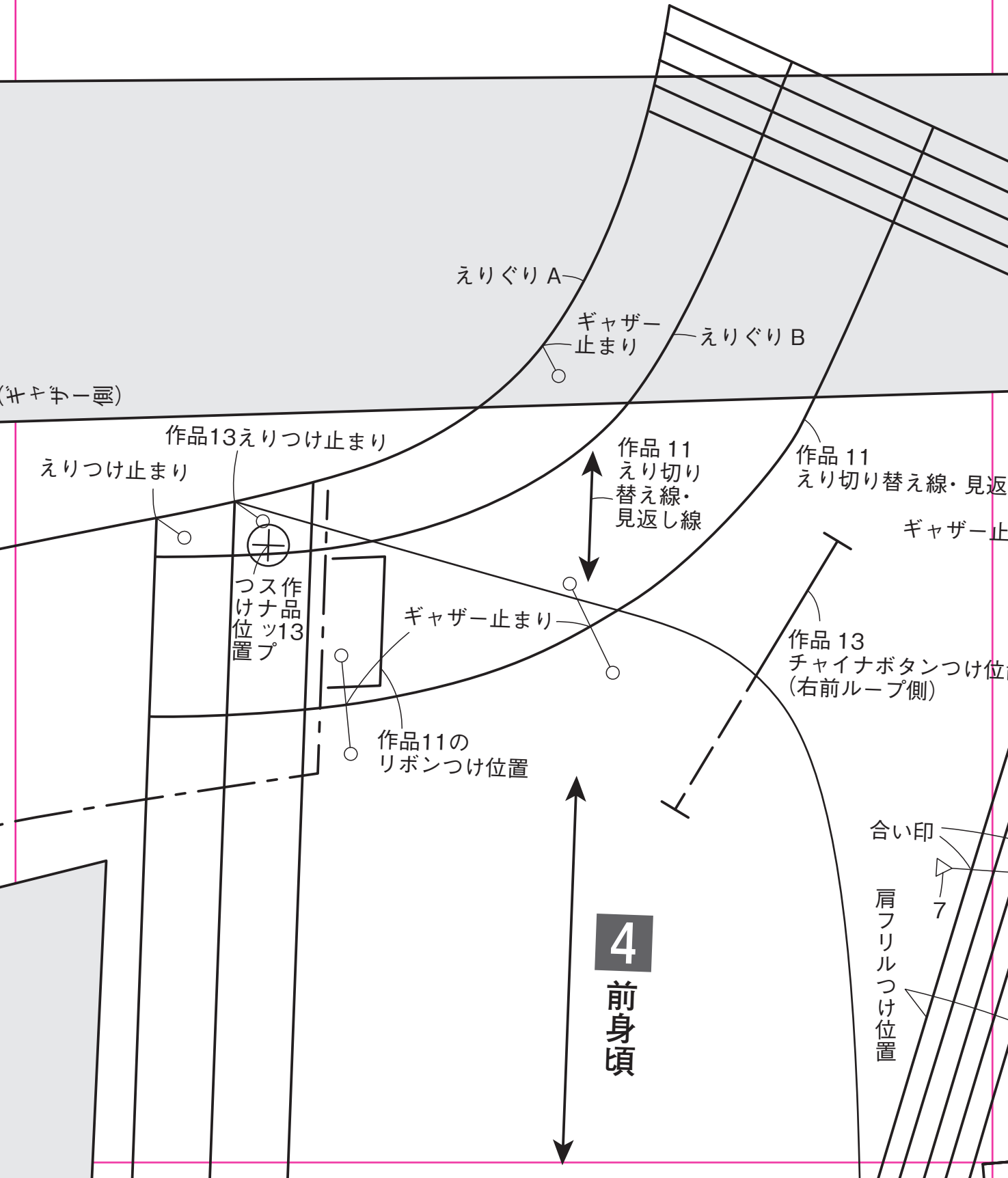

3

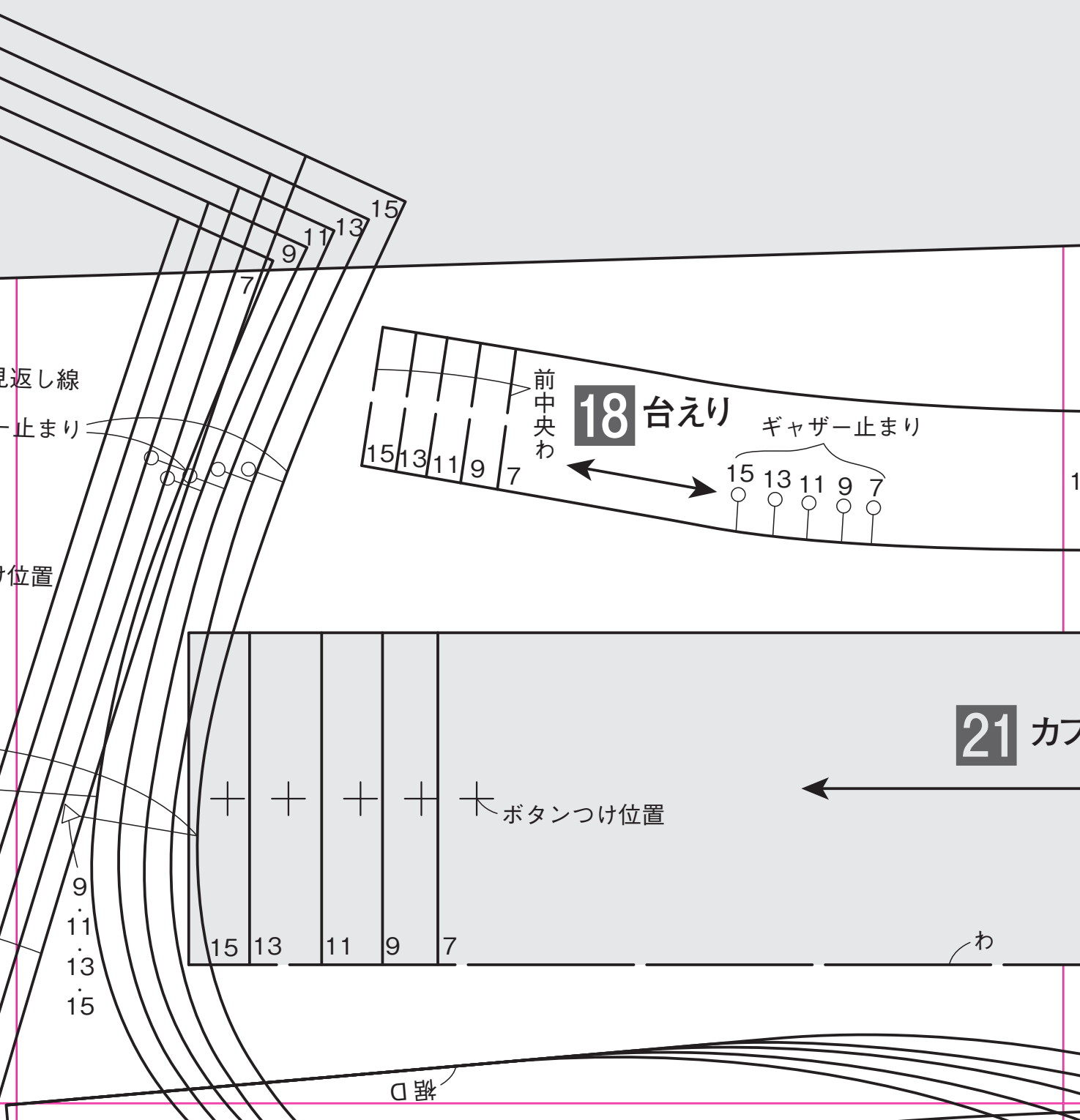

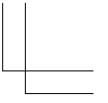

実物大型紙

b 面

4

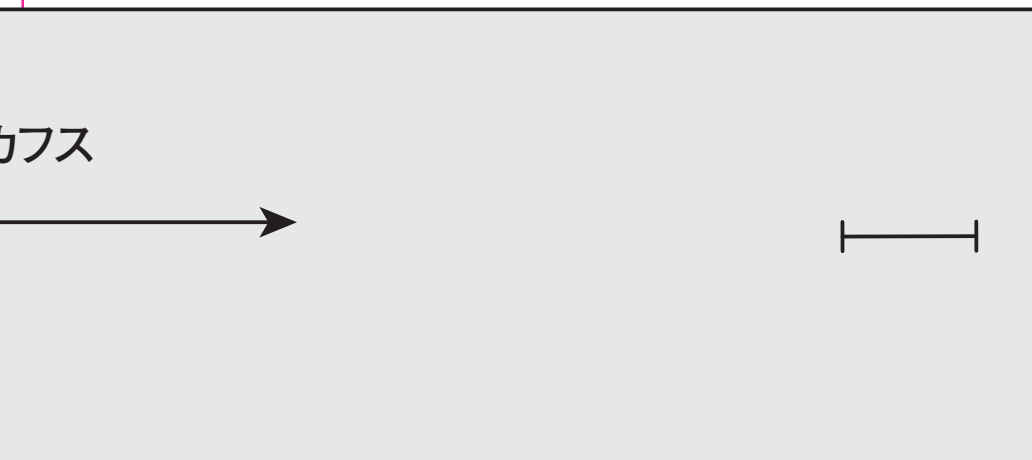
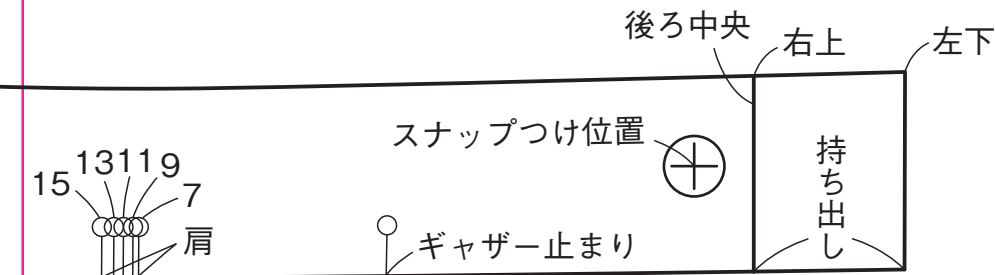

5

作品13
スナップつけ位置



作品13
スナップつけ位置



28

上フリル

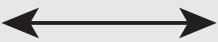

7・9・11

13・15

Aフリルつけ位置

前端

前中央

前立て切り替え線

6

7 9 11 13 15

7 9 11 13

7・9・11

13・15

Bフリルつけ位置

下フリルつけ止まり

上フリルつけ止まり

7 9 11 13 15

7・9・11

13・15



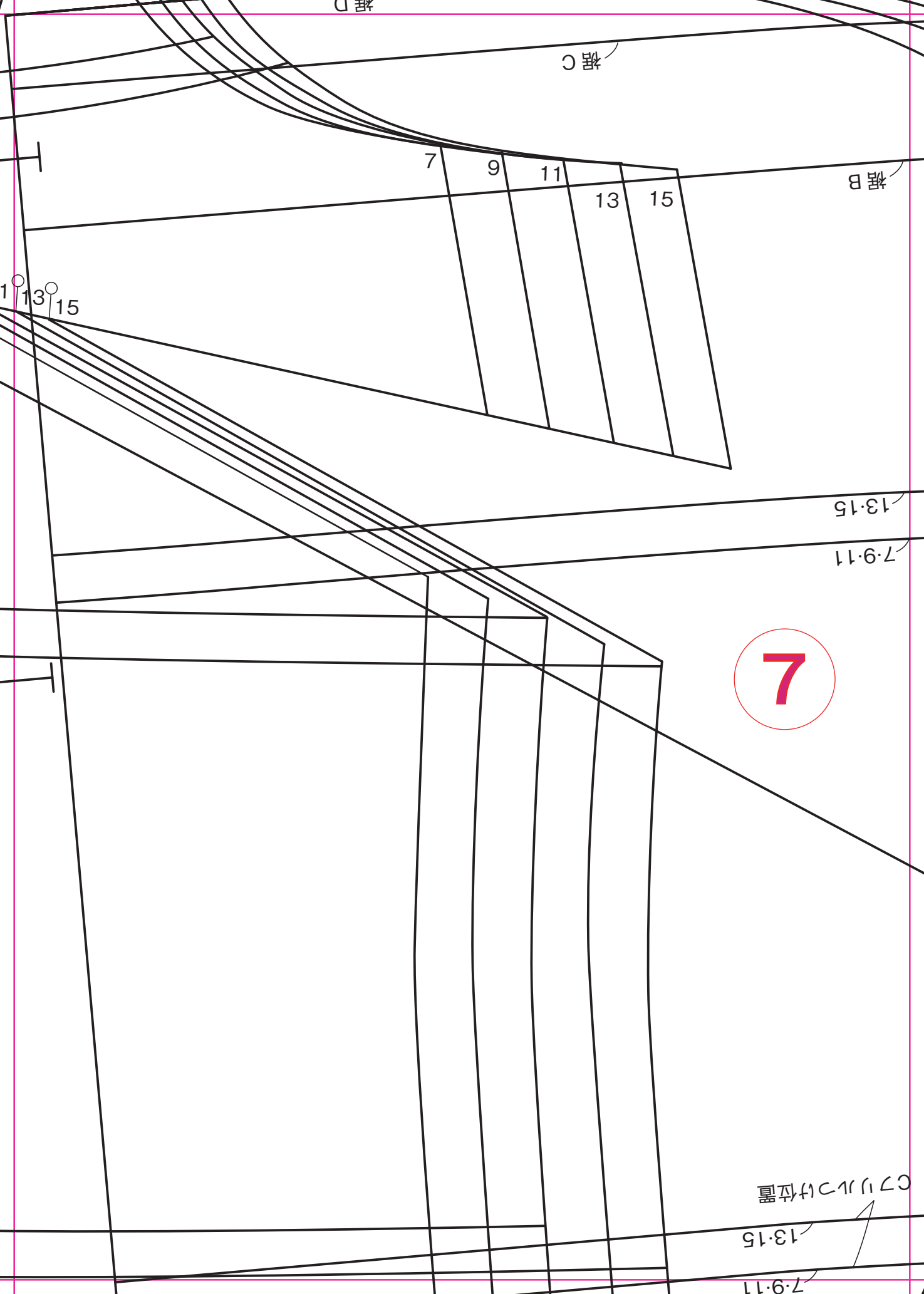

8

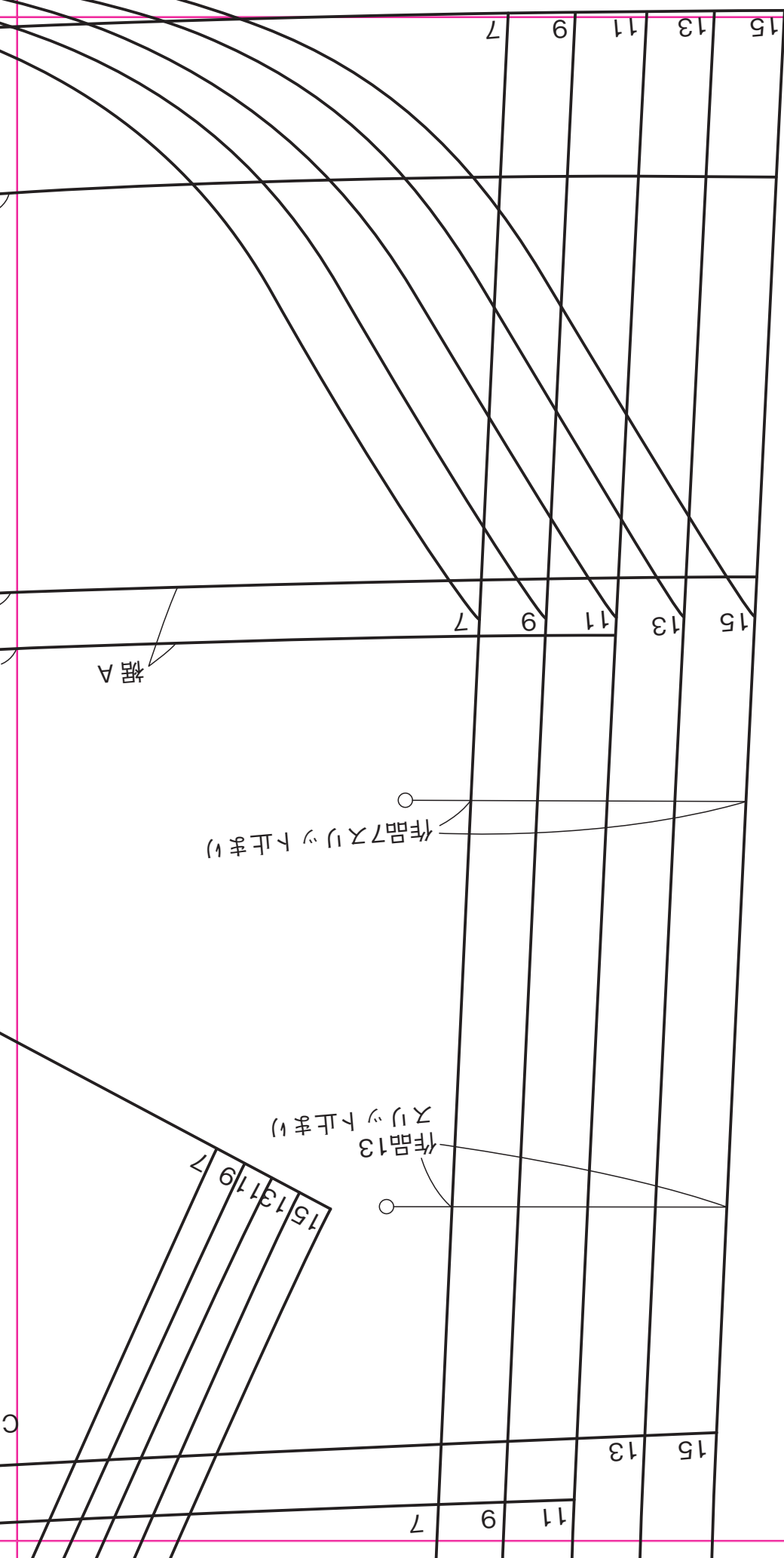

9

7
9
11
13
15

後方

印

Cフリルつけ位置

裾 A

7・9・11

13・15

10

裾 B

裾 D

裾 C

11.6.2

作品13スリット止まり



作品7スリット止まり



7 9 11 13 15

後の中

11

位置付けのり

13.15

7.9.11

7 9 11 13 15

151319 7



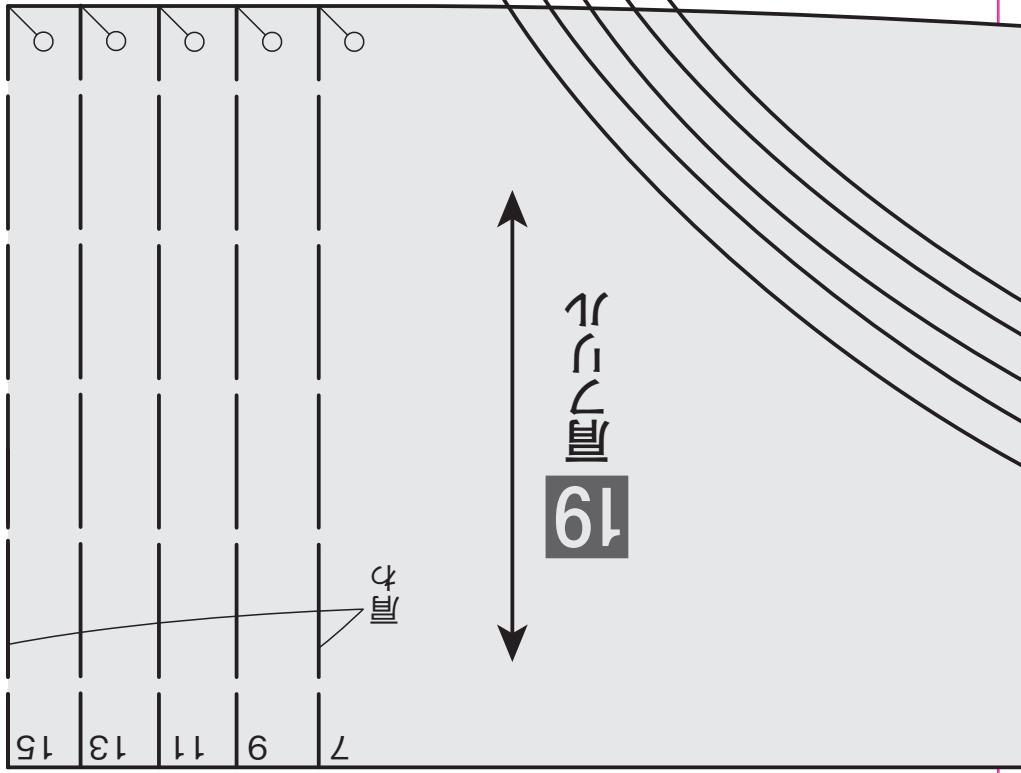

12 チャイナカラー

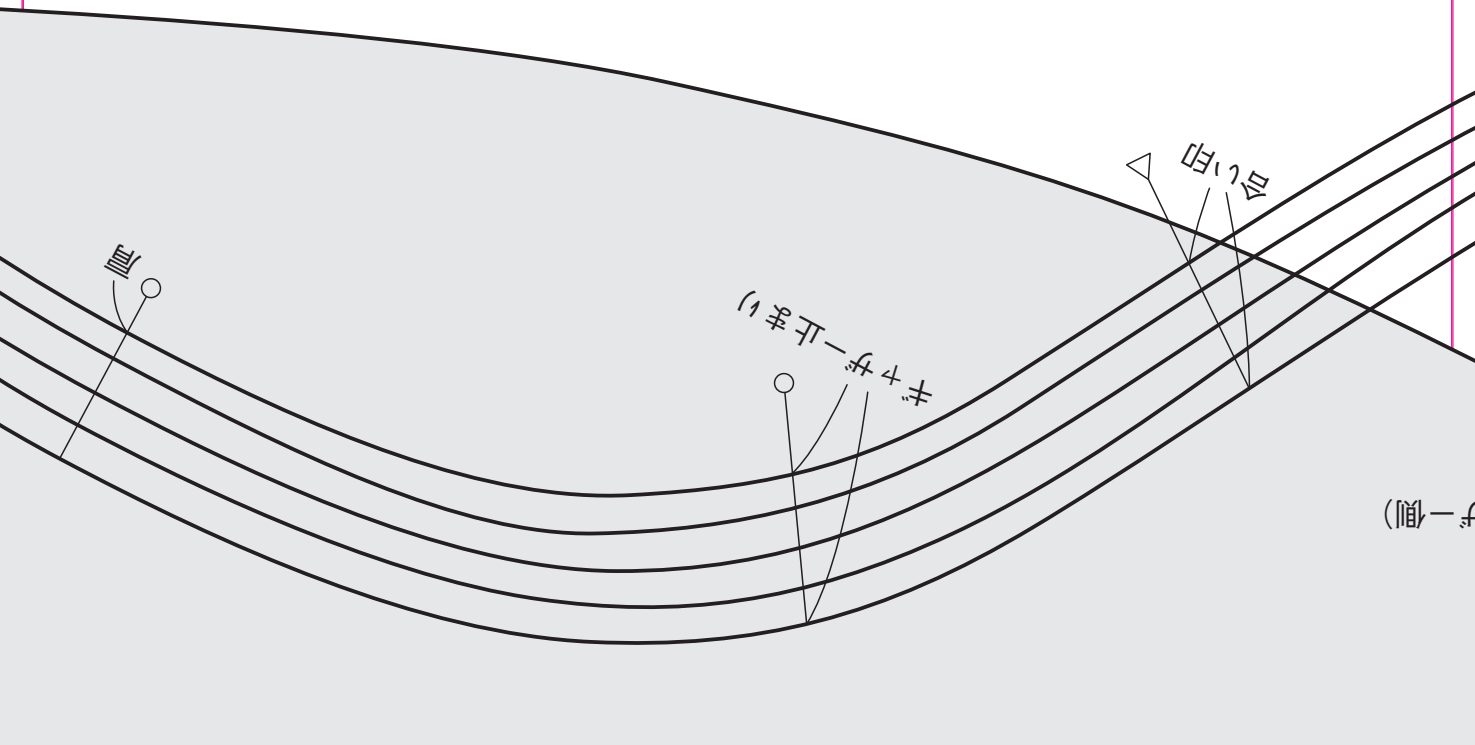
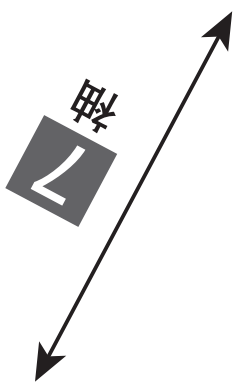
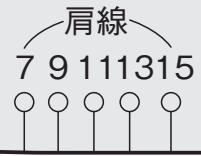
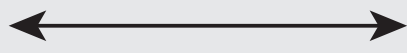

14

